

**OPERATOR'S AND ORGANIZATIONAL
MAINTENANCE MANUAL**

**INCLUDING REPAIR PARTS AND
SPECIAL TOOLS LIST
FOR
PLOTING BOARD, INDIRECT FIRE
M16 W/E (1220-00-602-7941)
AND
PLOTING BOARD, INDIRECT FIRE
M19 W/E (1220-01-059-7989)**

**HEADQUARTERS,
DEPARTMENT OF THE ARMY**

JULY 1981

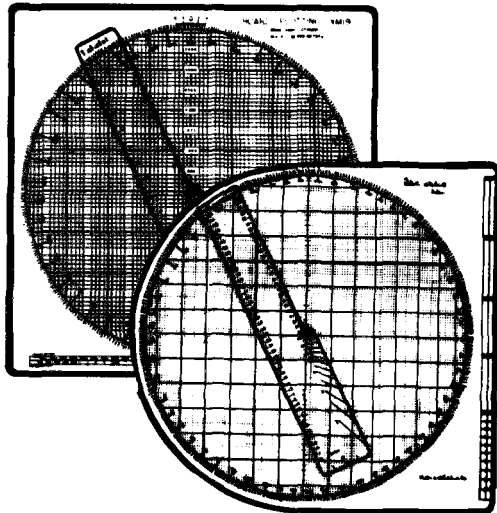

TECHNICAL MANUAL }
}

No. 9-1220-243-12&P

HEADQUARTERS
DEPARTMENT OF THE ARMY
WASHINGTON, DC, 10 JULY 1981

Operator's and
Organizational Maintenance Manual Including
Repair Parts and Special Tools List
For
PLOTTING BOARD, INDIRECT FIRE M16 W/E
(1220-00-602-7941)
PLOTTING BOARD, INDIRECT FIRE M19 W/E
(1220-01-059-7989)

Current as of 12 January 1981

"This manual supersedes TM 9-1220-204-14, 11 June 1971, including all changes.

REPORTING ERRORS AND RECOMMENDING IMPROVEMENTS.

You can help improve this manual. If you find any mistakes or if you know of a way to improve the procedures, please let us know. Mail your letter, or DA Form 2028 (Recommended Changes to Publications and Blank Forms), direct to: Commander, US Army Armament Materiel Readiness Command, ATTN: DRSAR-MAS, Rock Island, IL 61299. A reply will be furnished to you.

	Page
CHAPTER 1 INTRODUCTION	1-1
General Information	1-1
Basic Issue Items List (BILL)	1-2
Equipment Description and Data	1-3
2 OPERATING INSTRUCTIONS	2-1
Preventive Maintenance Checks and Services (PMCS)	2-1
Setting Up Plotting Board	2-1
Handling	2-1
How to Use the Plotting Board	2-2
Hints for Better Operation	2-6
Sample Problems	2-7
Operating Under Unusual Conditions	2-11

CHAPTER 3 MAINTENANCE INSTRUCTIONS	3-1
Lubrication Instructions	3-1
Troubleshooting	3-1
Maintenance Procedures	3-4
APPENDIX A REFERENCES	A-1
B MAINTENANCE ALLOCATION CHART	B-1
C REPAIR PARTS AND SPECIAL TOOLS LIST	C-1
Group 00 M16 Plotting Board w/e and M19 Plotting Board w/e	C-4
01 M16 Plotting Board and M19 Plotting Board	C-6
APPENDIX D EXPENDABLE SUPPLIES AND MATERIALS LIST	D-1

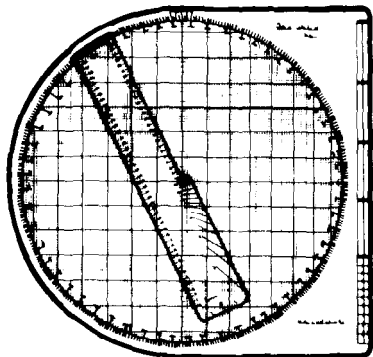

INDIRECT FIRE,
PLOTTING BOARD M16

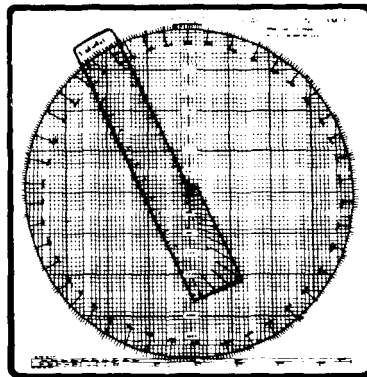

INDIRECT FIRE,
PLOTTING BOARD M19

CHAPTER 1

INTRODUCTION

GENERAL INFORMATION

Scope

Type of Manual. Operator's and organizational maintenance.

Model Number and Equipment Name.

M16 Indirect Fire Plotting Board

M19 Indirect Fire Plotting Board

Purpose of Equipment. The plotting board is an instrument used to compute the deflection, range, and azimuth for indirect firing of the mortar. The M16 plotting board is used with the 81-mm M29 and the M19 is used with the 60-mm M224 mortar.

Since the M16 and M19 plotting boards are so similar, only one operation and maintenance procedure will be shown.

GENERAL INFORMATION (Cont)

Maintenance Forms, Records, and Reports

Department of the Army forms and procedures used for equipment maintenance will be those prescribed by TM 38-750, The Army Maintenance Management System.

Reporting Equipment Improvement Recommendations (EIR)

If your plotting board needs improvement, let us know. Send us an EIR. You, the user, are the only one who can tell us what you don't like about your equipment. Let us know why you don't like the design. Tell why a procedure is hard to perform. Put it on SF 368 (Quality Deficiency Report). Mail it to us at Commander, US Army Armament Materiel Readiness Command, ATTN: DRSAR-MAO, Rock Island, IL 61299. We'll send you a reply.

BASIC ISSUE ITEMS LIST (BIIL)

The Basic Issue Items List (BIIL), Components of End Item List (COEIL), and Additional Authorization List (AAL) are not included in this TM. The plotting boards have no items which would appear on these lists. All expendable supplies and materials required are listed in Appendix D.

EQUIPMENT DESCRIPTION AND DATA

Weight and Dimensions

	<i>M16</i>	<i>M19</i>
Weight	3 lbs, 13 oz	2 lbs, 8 oz
Length	22 inches	14 inches
Width	21 1/2 inches	13 inches
Thickness	7/8 inch	1 inch

The plotting boards have the same basic components and operate in the same way. They differ in scale, dimension, and application.

Nomenclature Cross-Reference List

<i>Common Name</i>	<i>Official Nomenclature</i>	
	<i>M16</i>	<i>M19</i>
Base	Base	Panel assembly
Disk	Disk, Azimuth	Scale, plotting 11736209
Arm	Arm, Scale	Scale, plotting 11746805

Grid Scale

M16	1:12,500 METERS
M19	1:25,000 METERS

EQUIPMENT DESCRIPTION AND DATA (Cont)

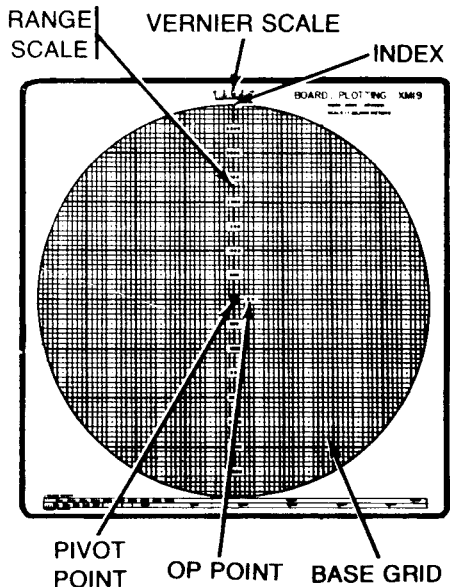
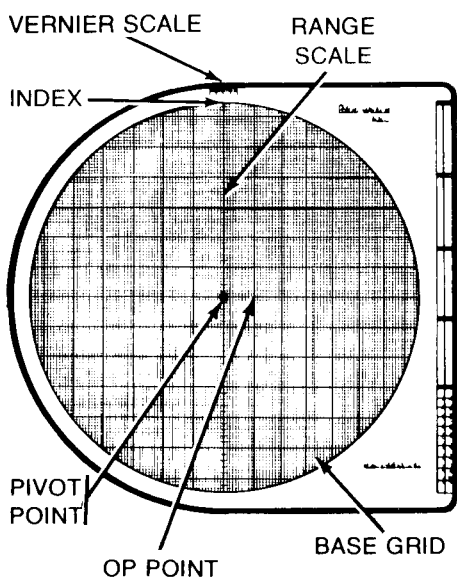

1-4 The base grid is graduated in meters and is used to determine range.

EQUIPMENT DESCRIPTION AND DATA (Cont)

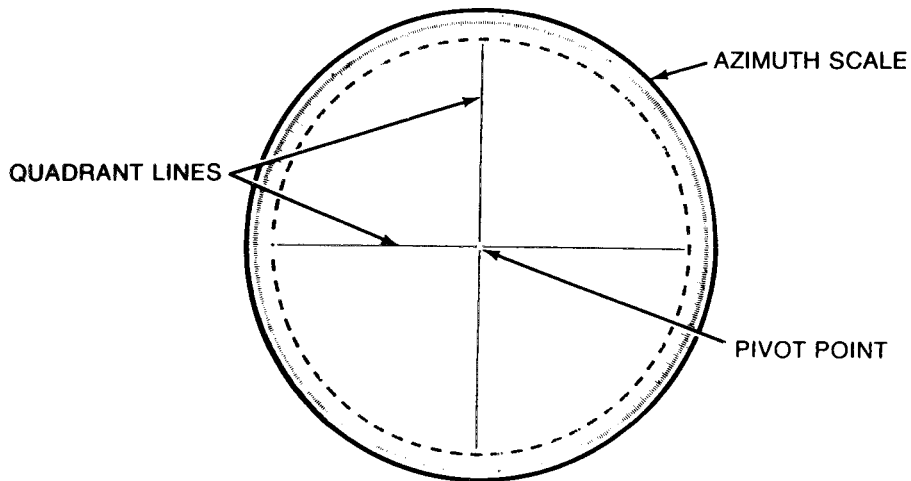

The azimuth scale is graduated in mils and is used to establish azimuth.

EQUIPMENT DESCRIPTION AND DATA (Cont)

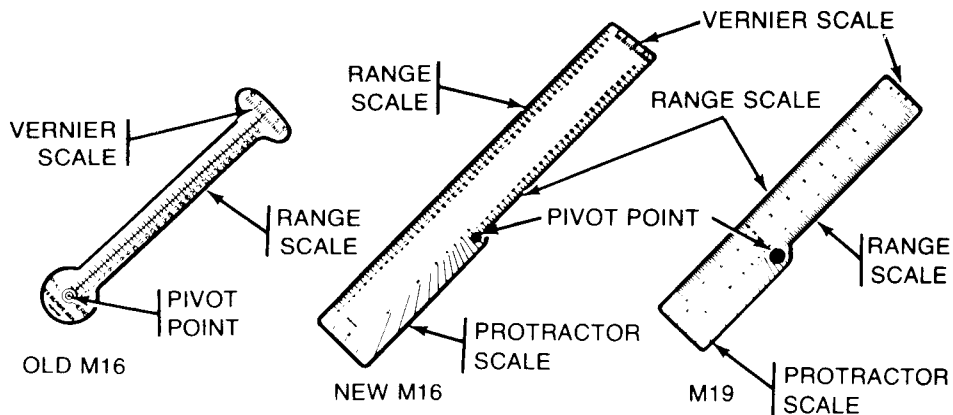

Arm

The range arm is used when the mortars are located at the pivot point and one or more missions are going on. The range scale on the arm is the same as the scale on the base.

The new design arm is used to determine range on the M16 and M19. The old arm is used only on the M16 and will be replaced when it becomes unserviceable by the new range arm.

EQUIPMENT **DESCRIPTION AND DATA (Cont)**

Case

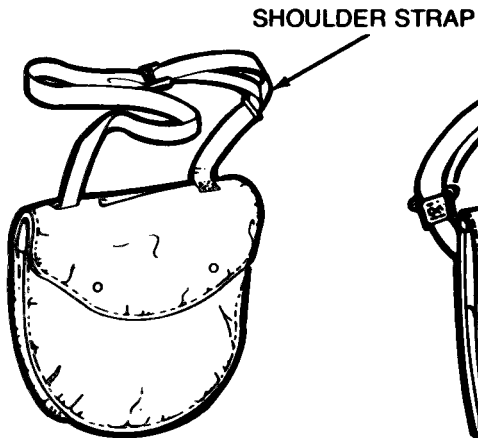

CASE FOR M16

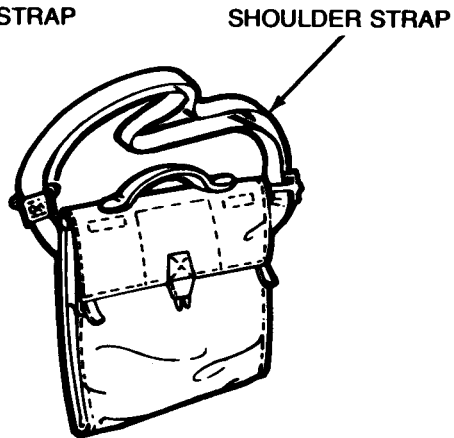

CASE FOR M19

CHAPTER 2

OPERATING INSTRUCTIONS

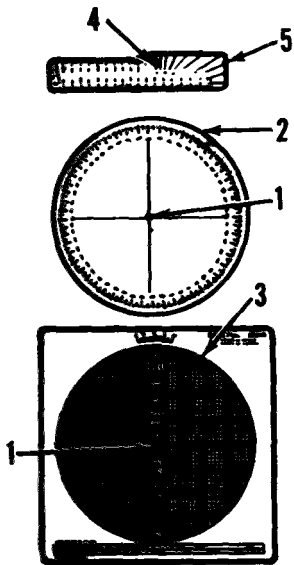

PREVENTIVE MAINTENANCE CHECKS AND SERVICES (PMCS)

The only PMCS needed for the plotting board is to keep it clean and dry, to stow it in the carrying case, and to lay it flat when in storage.

SETTING UP PLOTTING BOARD

1. Line up pivot points (1) of disk (2) and base (3) and press together.
2. Line up pivot point (4) of arm (5) with pivot points (1) and press together.

HANDLING

Handle the plotting board with care to prevent bending, scratching, or chipping. Avoid excessive heat or prolonged exposure to the sun which may cause the board to warp. When storing the board, place it in its carrying case, base down on a horizontal surface. Do not place the plotting board on end or store other equipment on it.

HOW TO USE THE PLOTTING BOARD

The plotting board is used to plot the positions of the mortars, observation points, and targets so you can determine the directions and distances between these points.

NOTE

Use the center (pivot point) of the plotting board as either the weapon position or the observation point.

To plot a point with a given azimuth and distance from another, proceed as follows:

1. Use the pivot point as one point.
2. Rotate the azimuth disk (1) on base grid (2) until the stated azimuth is indicated over the index mark (3).
3. Using the range scale (4) measure the stated distance from the pivot point toward the top of the plotting board and place a dot.

NOTE

In plotting, read right for azimuth and left for deflection.

HOW TO USE THE PLOTTING BOARD (Cont)

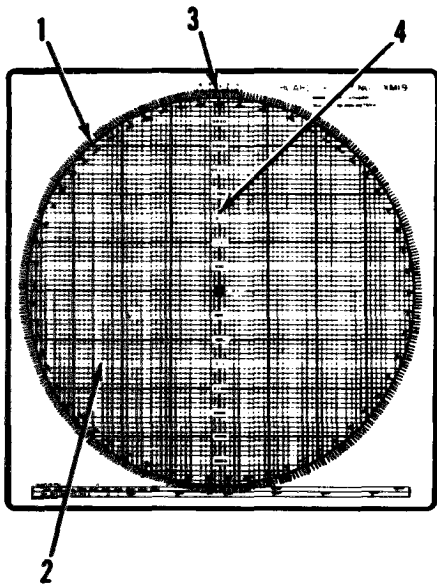

Repeat the procedure to plot a second location.

To find the azimuth and distance between the two plotted points proceed as follows:

1. Rotate the azimuth disk (1) until the two pencil dots lie along, or are the same distance from, one of the vertical lines on the base grid with the target dot toward the top of the plotting board.
2. Read the azimuth at the index marks (3).
3. Determine the range using the range scale (4).

HOW TO USE THE PLOTTING BOARD (Cont)

Using the Range Arm

The range scale (4) on grid (2) is the same as the range scales on range arm (5).

The range scale on the left edge of the range arm is provided for plotting problems from below center when the range arm (5) is removed. The arrow at 2000 meters indicates the vertex of a 3200 mil protractor when used to measure angles from maps.

To determine azimuth (a four digit number), read the first three digits on the azimuth disk scale to the right of the index mark on the range arm. The fourth digit is read from the right side of vernier (6). Starting at zero, the lines on the vernier (6) are counted off until the point where the vernier line coincides with a line on the azimuth disk (1).

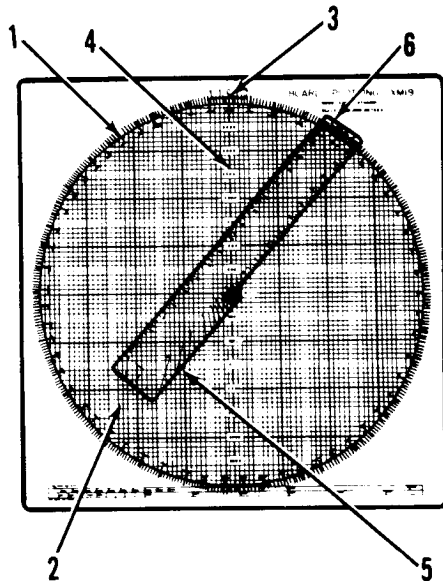

HOW TO USE THE PLOTTING BOARD (Cont)

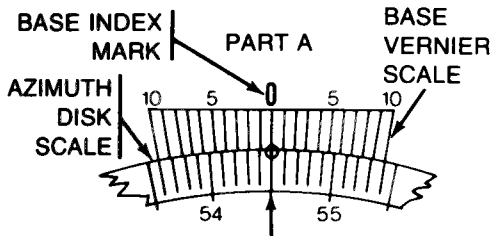

ALINE 5,450 GRADUATION WITH
VERNIER "0."

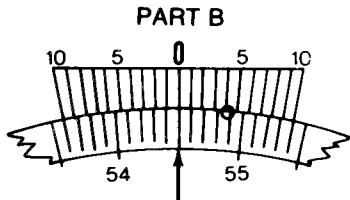

OBSERVE FOURTH VERNIER LINE TO
THE RIGHT OF "0" AND NOTE AZIMUTH
DISK GRADUATION ADJACENT (TO THE
RIGHT) TO THE VERNIER LINE.

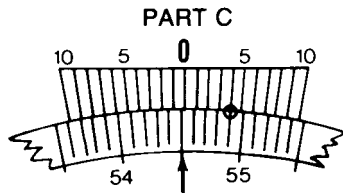

ROTATE AZIMUTH DISK TO ALINE
LINES OBSERVED IN PART B. POINT
OPPOSITE VERNIER "0" IS THE 5,454-
MIL AZIMUTH LOCATION.

Using the Vernier Scale

In many cases, the index mark does not fall exactly on one of the 10-mil graduation lines of the azimuth scale. When this occurs, the operator computing the range must use the vernier scale to read the azimuth to an accuracy of 1 mil. Using the vernier scale for setting azimuth 5454 is shown below as an example:

HINTS FOR BETTER OPERATION

Do not use map pins, needles, ink pens or grease pencils. Using these items will damage the board. Plotting should be done with a very sharp, soft lead pencil (No. 2 or softer). Be careful when placing a plot on the disk, for a very small plotting error could cause the final data to be off as much as 25 meters in range and more than 10 mils in deflection. To avoid distortion, you should place your eye directly over the location of a point and hold your pencil perpendicular to the board. The plot should be so small that it is difficult to see. For ease of identification, circle and number each plot.

SAMPLE PROBLEMS

NOTE

The following procedures are sample problems to demonstrate uses of the plotting board.

Determination of the Initial Azimuth and Range from the Weapon Firing Position to the Target.

Problem. Observation Post (OP) at the center (pivot point) of the disk.

OP to weapon: Azimuth 4150 mils
Distance 550 meters

OP to target: Azimuth 5454 mils
Distance 1500 meters

SAMPLE PROBLEMS (Cont)

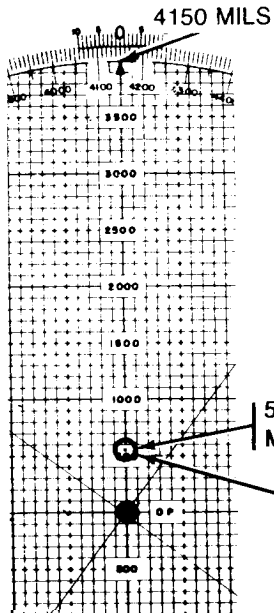

2-8

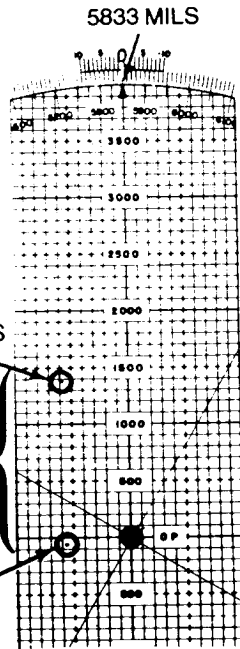
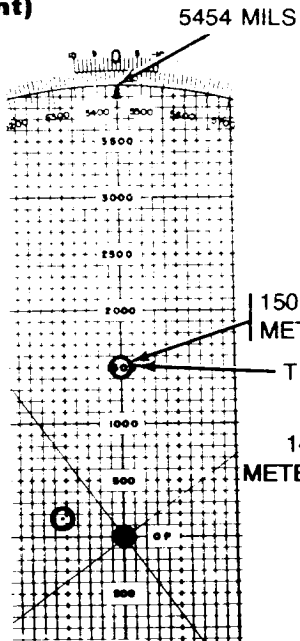

SAMPLE PROBLEMS (Cont)

Rotate the disk until 4150 mils is read over the index mark on the base. Mark the disk with a pencil dot over the index line at the 550-meter graduation. This dot represents the location of the weapon (W).

Rotate the disk until 5454 mils is read over the index mark on the base. Mark the disk with a pencil dot over the index line at the 1500-meter graduation. This dot represents the location of the target (T).

Rotate the disk until the two pencil dots are over, or parallel to, the same vertical line, or are the same distance from the same vertical line, with the dot representing the location of the target (T) toward the vernier scale.

Read the WT azimuth, at the index mark on the base, as 5633 mils. The total number of meters between the pencil dots when in this position (1400 meters above the horizontal OP line passing through the pivot plus 50 meters below) is the weapon-target range (WT) of 1450 meters.

NOTE

M19 scale is shown on page 2-8; M16 is in 50 meter increments.

SAMPLE PROBLEMS (Cont)

NOTE

Use the same procedures with different values

Determination of GT Mil Values from the Azimuth Scale on the Azimuth Disk.

Problem 1. Observation post at center (pivot point) of the disk.

Observer (O) to Target (T): Azimuth 800 mils
Distance 2500 meters

Observer (O) to Gun (G): Azimuth 2500 mils
Distance 1250 meters

GT = 348 mils.

Problem 2. Observation post at center (pivot point) of the disk.

Observer (O) to Target (T): Azimuth 5900 mils
Distance 3200 meters

Observer (O) to Gun (G): Azimuth 3850 mils
Distance 1050 meters

GT = 6159 mils.

OPERATION UNDER UNUSUAL CONDITIONS

Cold (Below Freezing)

Be extra careful handling the board. Cold makes the plastic material more brittle, and therefore more easily cracked or broken.

Use a dry cloth for cleaning. A damp cloth will leave a film of ice.

Dusty or Sandy Conditions

When handling and cleaning the board, be extra careful not to scratch its plastic surfaces. Scratching will destroy the transparencies of the base grid or disk surfaces. Scratching could also wipe out the lines of the vernier and scale.

Shake dust and sand out of the carrying case.

CHAPTER 3

MAINTENANCE INSTRUCTIONS

LUBRICATION INSTRUCTIONS

All required lubrication is performed during assembly operations.

TROUBLESHOOTING

This troubleshooting table can't list all possible malfunctions or corrective actions. See your supervisor for any problems not in the table.

MALFUNCTION

TEST OR INSPECTION

CORRECTIVE ACTION

1. BASE DOES NOT LAY FLAT ON TABLE.

Check for bent, broken, or scarred grid surface.

Replace plotting board.

TROUBLESHOOTING (Cont)

MALFUNCTION

TEST OR INSPECTION

CORRECTIVE ACTION

2. MARKING ON BASE CANNOT BE READ.

Check base for illegible grid and marking.

Replace plotting board.

3. BASE MARKING DOES NOT ALINE PROPERLY WITH DISK MARKING.

Check base for worn bushing.

Replace plotting board.

4. MARKING ON DISK CANNOT BE READ.

Check disk for illegible marking and seared. surface

Replace disk as shown on page 3-5.

TROUBLESHOOTING (Cont)

MALFUNCTION

TEST OR INSPECTION

CORRECTIVE ACTION

5. MARKING ON DISK DOES NOT ALINE PROPERLY WITH BASE MARKING.

Check disk for worn pivot point.

Replace disk as shown on page 3-5.

6. MARKING ON ARM CANNOT BE READ.

Check arm for illegible marking.

Replace arm as shown on page 3-4.

7. MARKING ON ARM DOES NOT ALINE PROPERLY WITH BASE AND DISK MARKING.

Check for worn or bent pivot point.

Replace arm as shown on page 3-4.

MAINTENANCE PROCEDURES

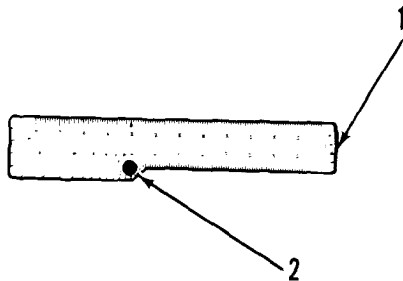
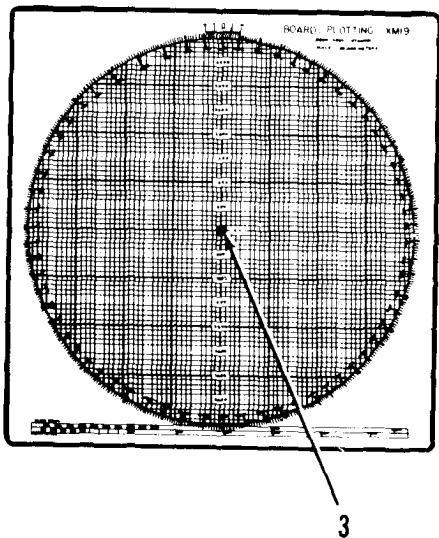

Removing Range Arm

Grasp arm (1) by pivot point (2) and lift to remove.

Installing Range Arm

First install disk. Then line up arm pivot point (2) with base pivot point (3) and press together.

MAINTENANCE PROCEDURES (Cont)

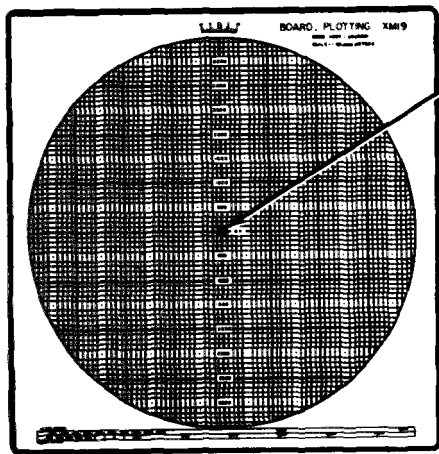

Removing Disk

To remove disk from plotting board place hands under opposite sides of disk and lift.

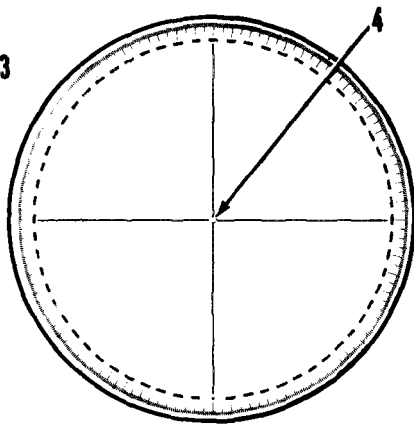

Installing Disk

To install, line up disk pivot point (4) with base pivot point (3) and press together.

MAINTENANCE PROCEDURES (Cont)

Cleaning/Lubricating the Plotting Board

Clean components of plotting board with soap and water. Wipe dry with a soft cloth.

Lubricate pivot points with aircraft grease (item 1, app D).

APPENDIX A

REFERENCES

TM 9-1010-223-10 Operator's Manual for Lightweight Company Mortar 60mm, M224

TM 9-1015-200-12 Operator's and Organizational Maintenance Manual: Mortar, 81mm:
M29, M29A1

FM 23-91 Mortar Gunnery

APPENDIX B

MAINTENANCE ALLOCATION CHART

GENERAL

The maintenance allocation chart indicates specific maintenance operations performed at the proper maintenance levels.

GROUP NUMBER (COLUMN 1)

The group number matches the functional group code which appears at the top of the RPSTL listing.

MAINTENANCE LEVEL CODE (COLUMN 4)

Code	Explanation	Code	<i>Explanation</i>
C	Operator/Crew Maintenance	H	General Support Maintenance
O	Organizational Maintenance	D	Depot Maintenance
F	Direct Support Maintenance		

REMAINING COLUMNS (COLUMNS 2, 3, 5, AND 6)

Columns 2, 3, 5, and 6 are self-explanatory.

MAINTENANCE ALLOCATION CHART

(1) GROUP NUMBER	(2) COMPONENT ASSEMBLY	(3) MAINTENANCE FUNCTION	(4) MAINTENANCE LEVEL					(5) TOOLS AND EQPT.	(6) REMARKS
			C	O	F	H	D		
00	M16 PLOTTING BOARD W/E	Service Replace Repair	0.1	0.2 0.1					
00	M19 PLOTTING BOARD W/E	Service Replace Repair	0.1	0.2 0.1					
01	M16 PLOTTING BOARD W/O	Service Replace	0.1	0.2					
01	M19 PLOTTING BOARD W/O	Service Replace	0.1	0.2					

APPENDIX C

REPAIR PARTS AND SPECIAL TOOLS LIST

GENERAL

This appendix lists repair parts required for performance of organizational maintenance of the M16 and M19 Plotting Boards. It authorizes the requisitioning and issue of repair parts as indicated by the source and maintenance codes. There are no special tools for this item.

SOURCE, MAINTENANCE, AND RECOVERABILITY (SMR) CODES (COLUMN 2)

<i>Source Code</i>	<i>Maintenance Code</i>	<i>Recoverability Code</i>	
XX	X	X	X
How you get the item.	Who can replace (order) the item	Who can repair the item	Who disposes of an unserviceable item.

**SOURCE, MAINTENANCE, AND RECOVERABILITY (SMR) CODES
(COLUMN 2)**

Source Codes:

PA Stocked item. You can order it.

XA Not stocked. You can't order it... you must order the next highest assembly.

Maintenance Codes:

Position 3: O Organizational Level Maintenance.

Position 4: O Return to organizational level for repair.

Z No repair is authorized.

Recoverability Code:

Z When unserviceable, return to level indicated in position 3 for condemnation and disposal.

O When nonreparable, return to organizational level for condemnation and disposal.

NATIONAL STOCK NUMBER (COLUMN 3)

Use the NSN for requisitioning.

FEDERAL SUPPLY CODE FOR MANUFACTURER (FSCM) (COLUMN 4)

Identifies the manufacturer or whoever it is that supplies the item.

ILLUSTRATION ITEM NUMBER (COLUMN 1), DESCRIPTION AND PART NUMBER (COLUMN 5), AND QUANTITY INCORPORATED IN UNIT (COLUMN 6)

These columns are self-explanatory. The unit of issue for every item in this TM is "each." Usable on codes are shown in the description column. Identification of the codes in this publication is:

Code Used On

621 Plotting Board, Indirect Fire M16

L12 Plotting Board, Indirect Fire M19

REPAIR PARTS LIST

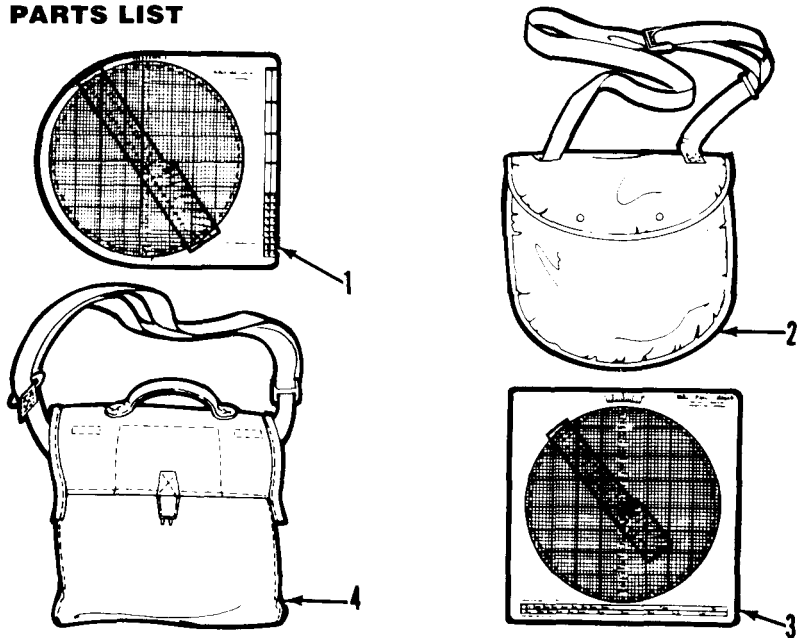

C-4

Figure C-1. M16 and M19 plotting boards w/le

REPAIR PARTS LIST(CONT)

(1)	(2)	(3)	(4)	(5)	(6)	
ILLUS ITEM NO.	SMR CODE	NATIONAL STOCK NUMBER GROUP 00	FSCM M16 M19	DESCRIPTION AND PART NUMBER	USABLE ON CODE	QTY INC IN UNIT
1	XA000		19200	PLOTTING BOARD INDIRECT FIRE, M16 7633931	621	1
2	PAOZZ	1220-00-613-8532	19200	CASE,CARRYING M105 7680317	621	1
3	XA000		19200	PLOTTING BOARD INDIRECT FIRE,M19 11746801	L12	1
4	PAOZZ	1220-01-055-6137	19200	CASE, PLOTTING BOARD 11733754	L12	1

REPAIR PARTS LIST (Cont)

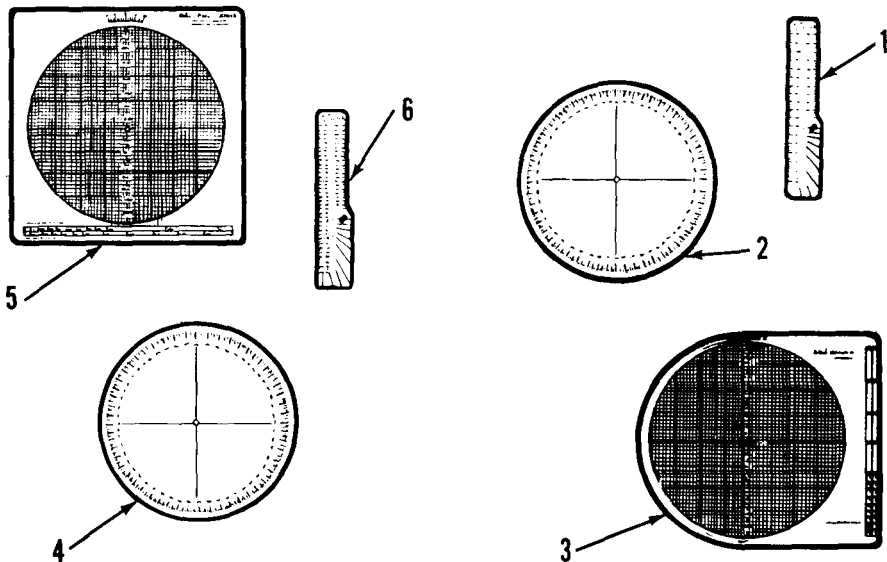

C-6

Figure C-2. M16 and M19 plotting boards

REPAIR PARTS LIST (CONT)

(1)	(2)	(3)	(4)	(5)		(6)
ILLUS ITEM NO.	SMR CODE	NATIONAL STOCK NUMBER	FSCM	DESCRIPTION AND PART NUMBER	USABLE ON CODE	QTY INC IN UNIT
		GROUP 01	M16	PLOTTING BOARD AND		
1	PAOZZ	1220-00-613-8533	M19 19200	PLOTTING BOARD SCALE ARM 7681435	621	1
2	PAOZZ	1220-00-756-3757	19200	DISK, AZIMUTH 7633933	621	1
3	XAOZZ		19200	BASE 7632523	621	1
4	PAOZZ	6675-01-077-4377	19200	SCALE, PLOTTING 11736209	L12	1
5	XAOZZ		19200	PANEL ASSEMBLY 11746802	L12	1
6	PAOZZ	6675-01-077-4376	19200	SCALE, PLOTTING 11746805	L12	1

APPENDIX D

EXPENDABLE SUPPLIES AND MATERIALS LIST

GENERAL

This appendix lists expendable supplies and materials you will need to operate and maintain the plotting board. These items are authorized to you by CTA 50-970, Expendable Items.

COLUMN 2, LEVEL

This column identifies the lowest level of maintenance that requires the listed item.

C Operator/Crew Maintenance

COLUMN 3, NATIONAL STOCK NUMBER

This is the National stock number assigned to the item; use it to request or requisition the item.

REMAINING COLUMNS (COLUMNS 1, 4, AND 5)

Columns 1, 4, and 5 are self-explanatory.

EXPENDABLE SUPPLIES AND MATERIALS LIST

(1)	(2)	(3)	(4)	(5)
-----	-----	-----	-----	-----

ITEM NUMBER	LEVEL	NATIONAL STOCK NUMBER	DESCRIPTION	U/M
1	C	9150-00-985-7244	GREASE, AIRCRAFT: (81349) MIL-G-23827 4 OZ TUBE	EA

By Order of the Secretary of the Army:

E. C. MEYER
General, United States Army
Chief of Staff

Official:

ROBERT M. JOYCE
Brigadier General, United States Army
The Adjutant General

Distribution:

To be distributed in accordance with DA Form 12-41 Operator maintenance requirements for Board, Plotting.

TM 9-1220-243-12&P

**PLOTTING BOARD, INDIRECT FIRE M16 W/E
AND M19 W/E**

PIN : 049479-000